

SL50W-3

This machine offers tremendous stability and is Shantui's best seller.

- ▶ Engine model: Shangchai C6121ZG50
- ▶ Rated power: 162 kw
- ▶ Operating weight: 17 t

Product Features

This series is Shantui's best-selling wheel loader. It offers tremendous stability and has pilot controls designed for reduced work intensity and increased safety and comfort for the operator. It has an advanced Z-type reverse tipping mechanism with large breakout force and high efficiency. It also has the latest in dual pump (combined) technology to improve fuel savings and work efficiency. The "3" stands for third generation, and it comes standard with a Dongfeng Cummins engine.



SHANTUI®

VALUE THAT WORKS

**CATICBJ-Shantui Construction Machinery
(E.A.) Co. Ltd.**

ADDRESS: Mombasa Road / Next to Tuffsteel,
P.O. Box 50724-00100, Nairobi, Kenya

TEL: +254 706 348 755





EMAIL: sales@caticbj-shantui.com

WEBSITE: www.shantui.com

SL50W-3

Technical specifications:

SL50W-3

	GENERAL SPECIFICATIONS	Operating weight (kg)	17000			
		Dimensions (L x W x H) (mm)	8040 x 3050 x 3430			
		Center distance of tires (mm)	2250			
		Wheel base (mm)	3250			
		Max. lifting force (KN)	200			
		Gradeability (°)	30			
		Min. turning radius (mm)	6025			
	ENGINE	Model	Shanghai C6121ZG50			
		Rated power (kw)	162			
		Rated revolutions (rpm)	2200			
		Displacement (L)	10.45			
		Min. fuel consumption (g/kw.h)	202			
		Max. torque (NM)	908			
	BUCKET	Turning angle (°)	36			
		Dumping reach (mm)	1160			
		Hydraulic system pressure (Mpa)	18			
		Loading capacity (t)	5			
		Bucket capacity (m³)	3			
		Bucket dump height (mm)	3178			
		Lift time, dumping/lowering (S)	10.7			
	TRAVEL SPEED	Gear	1st	2nd	3rd	4th
		Forward (km/h)	0-6.54	0-10.5	0-23.12	0-40.53
		Reverse (km/h)	0-6.54	0-10.5	0-23.12	

OVERALL DIMENSIONS

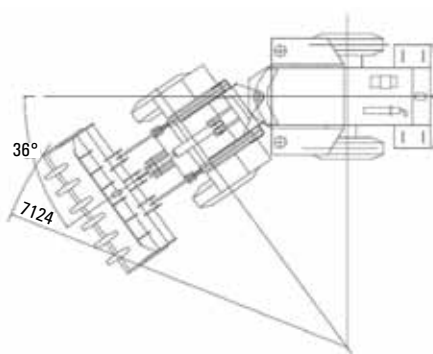
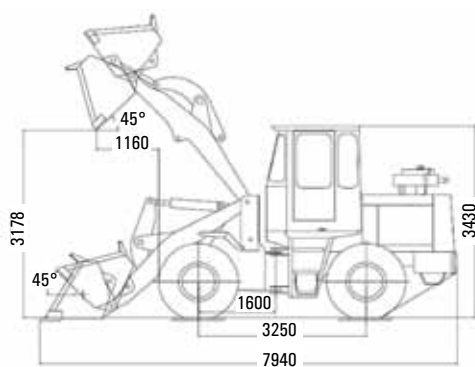

▶ THE SPECIFICATIONS ARE SUBJECT TO CHANGE WITHOUT NOTICE. THE PICTURES MAY INCLUDE OPTIONS. THE ACTUAL COLOR & APPEARANCE OF THE PRODUCT MAY DIFFER FROM WHAT IS SHOWN.